



HIGH PRECISION MACHINERY MANUFACTURER



QUALITY COMES FROM CONFIGURATION, SERVICE COMES FROM HEART

HONGKONG BAOFENG PRECISION MACHINERY CO.,LTD. : Hongkong: Room B1, 2/F, Mei Hing Industrial Building,
DONGGUAN BAOKE PRECISION MACHINERY CO.,LTD. : 16-18 Hing Yip Street, Kwun Tong, Kowloon, Hong Kong.
HUBEI BAOKE INTELLIGENT EQUIPMENT CO.,LTD. : Production base 1: No.63, XinMaLian Xintai road, Dalang
Town, DongGuan, China.
Production base 2: No.8, CaiBian South Second street,
Dalang Town, DongGuan, China.
Production base 3: East Optics Valley High-end Tool and
Mold Industrial Zone, Optics Valley Avenue No.1, Tieshan
District, Huangshi, Hubei, China.

0769-85633926
0769-82787859
info@baofengmachine.com
http://www.baofengmachine.com/

DONGGUAN BAOKE PRECISION MACHINERY CO.,LTD.

About BAOFENG

DONGGUAN BAOKE PRECISION MACHINERY CO., LTD. is a national high-tech enterprise, committed to the production and sale of CNC machining center. Our brand "BAOFENG MACHINE" integrates R&D, design, manufacturing, sales and service, and specializing in the field of high-quality CNC machining center including vertical, horizontal, double column, CNC drilling tapping centers, CNC engraving and milling machines.

Our headquarter is in Dongguan, China, now we have 6 factories, with advanced production equipment and high-precision testing equipment, such as the UK Renishaw laser interferometer, ball bar, Taiwan G-tech dynamic balancer, Germany Carl Zeiss three coordinates machine to ensure machines to be of high quality.

We also have an excellent technical team and CNC technology application center, to provide technical training and support for customer. From concept to prototype to mass production, we adhere to high-quality professional machine manufacturing and continuously innovates to meet market demand, providing customers with more competitive solutions and efficient service.



Whole machine assembly workshop



Machine body assembly workshop

01

HIGH STANDARD PRODUCTION PROCESS



High precision detection set



- Collimeter Inspection
Ensure straightness and parallelism of guideway



- The machine body adopts high strength HT300 gray casting iron through more than six months of aging treatment after high temperature tempering, which could eliminate the internal stress by maximum.



- All rail mounting surfaces through milling and grinding to ensure excellent precision and contact rates above 90%



- Germany Carl Zeiss Contura-7106 three coordinates machine



- England Renishaw round tester detection

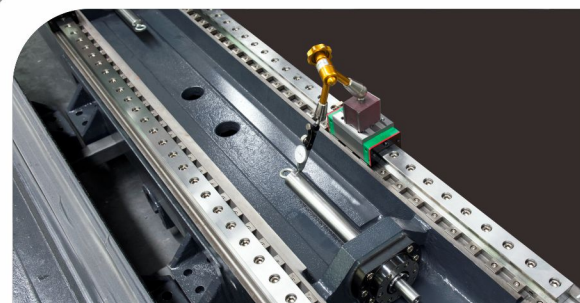

- Adopt Japanese NSK/THK ball screw, assembled by experienced engineer, strictly control the straightness of the screw nut.



- All joint surfaces of the machine body through manual scraping to ensure geometric accuracy and contact surface rigidity.



- England Renishaw laser interferometer



- Taiwan G-tech Fieldpaq Dynamic Balancer

02

HIGH SPEED HIGH PRECISION GANTRY MACHINING CENTER

Mechanical Features

- Integrated casting double box reinforced ribs gantry structure, connect the beam and the base effectively, which could enhance the rigidity of the whole machine.
- The base and worktable adopt box-type reinforced ribs to ensure the long time dynamic load performance without deformation.
- Axis adopt linear guideway, sliders for each XZ axis and sliders for Y axis, with high precision and heavy cutting performance.
- Axis linear scale full closed-loop detection system to ensure long-time heavy-duty processing without precision tolerance caused by thermal deformation of the transmission structure. (Optional function)



Japan NSK ball screw / Germany Rexroth linear guideway



Linear scale 3 axis with optional fully closed loop inspection system



Standard spindle
BBT40-12000 Direct drive
Optional spindle
1.BBT50-10000 Direct drive
2.HSK63A-18000 Direct drive
3.HSK63A-24000 Built-in type

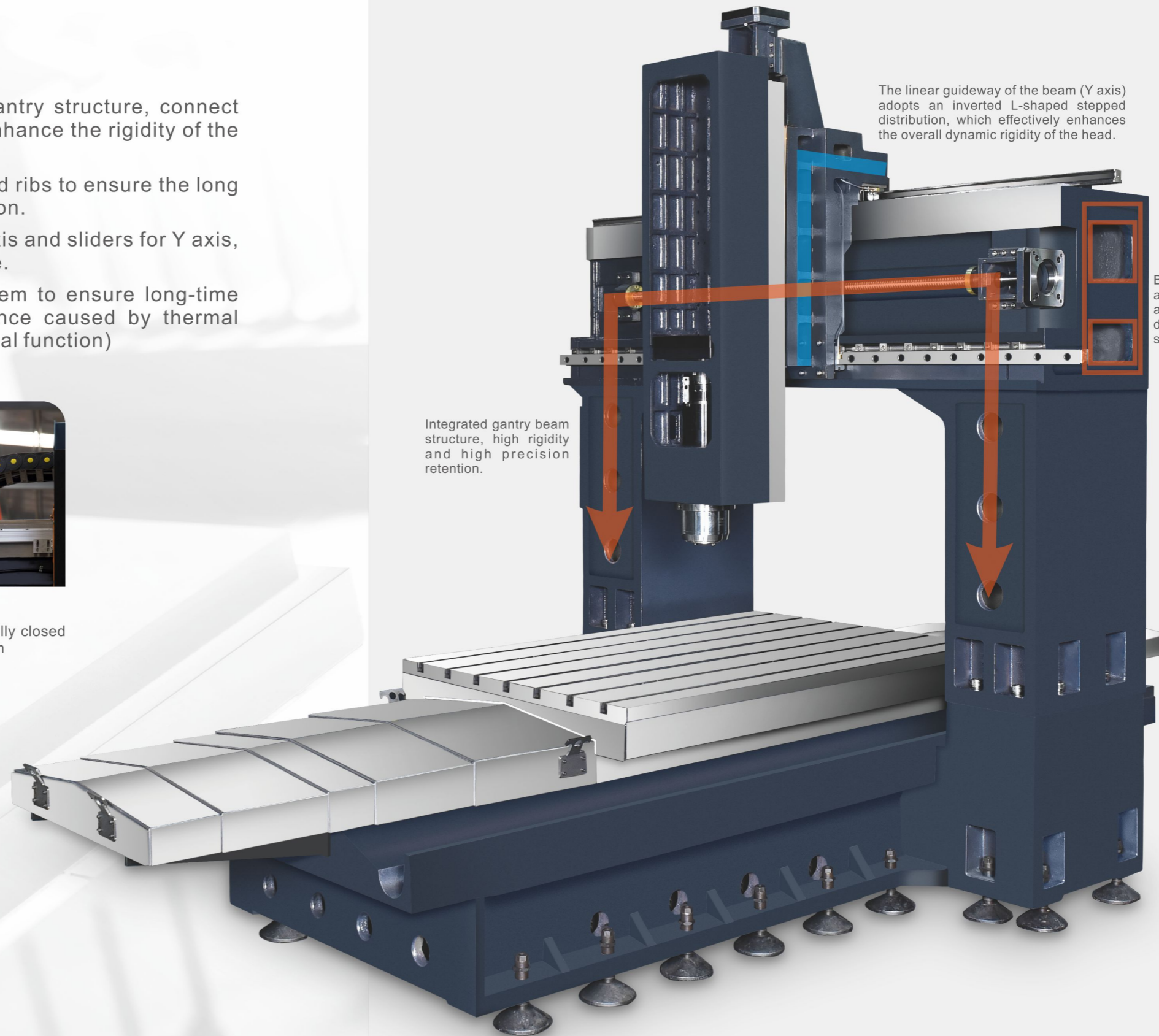

The linear guideway of the beam (Y axis) adopts an inverted L-shaped stepped distribution, which effectively enhances the overall dynamic rigidity of the head.

Base, worktable and gantry beam all adopt box-way double-layered structure.

Integrated gantry beam structure, high rigidity and high precision retention.

03

HIGH SPEED HIGH PRECISION GANTRY PROCESSING CENTER SERIES



Max. processing range and load

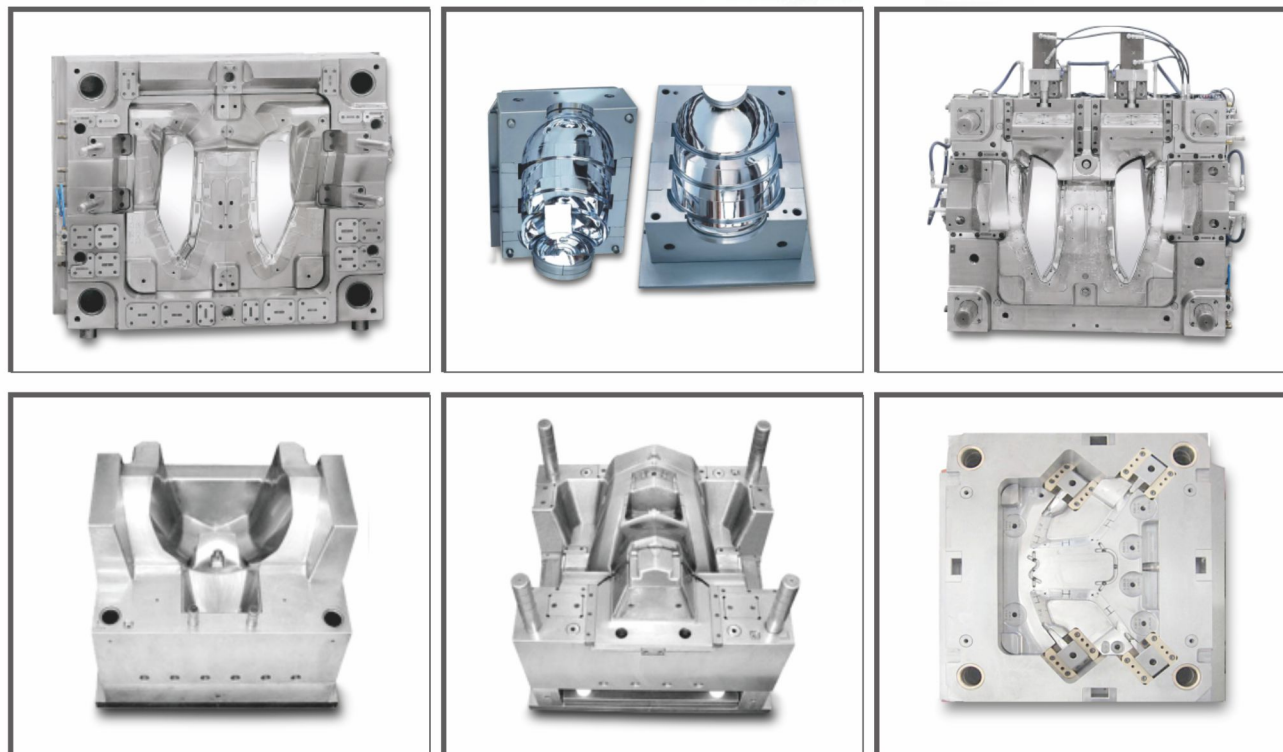
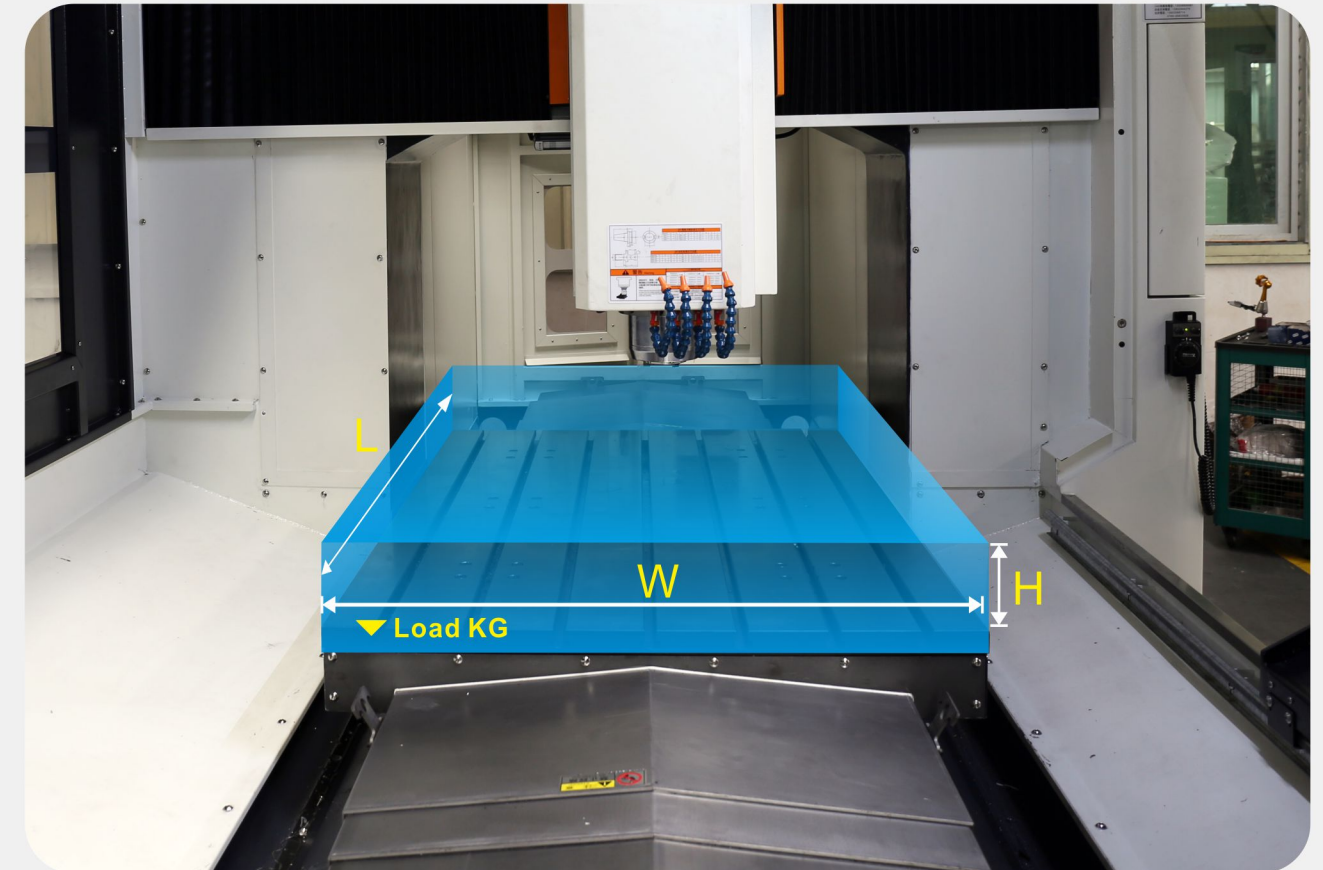

Model	Unit	L	W	H	Load
BF-1613VP	mm	1600	1400	600	3000KG
BF-2016VP	mm	2000	1600	800	5000KG
BF-2518VP	mm	2600	1800	900	8000KG

Output [kW]

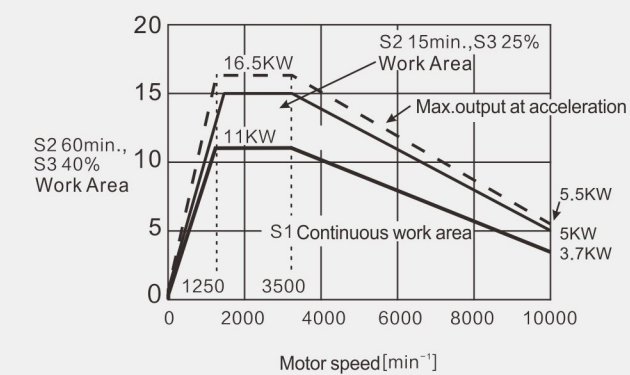

Torque [N.m]

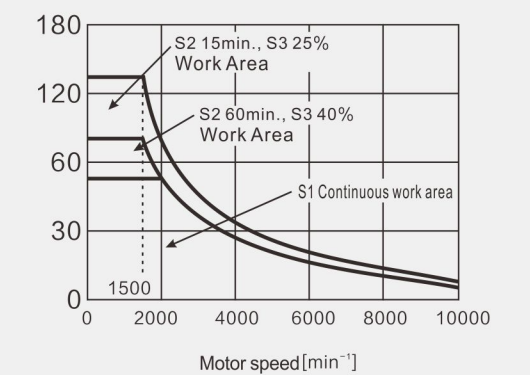

Standard spindle motor power/torque characteristics

04

HIGH SPEED HIGH HEAVY CUTTING GANTRY MACHINING CENTER

Mechanical Features

- Integrated casting + double box reinforced ribs gantry structure, connect the beam and the base effectively, which could enhance the rigidity of the whole machine.
- The base and worktable adopt box-type reinforced ribs to ensure the long time dynamic load performance without deformation.
- 3 axis of VP series are designed with roller linear guideways, while Z axis is surrounded by four-linear guideway for optimum precision and heavy cutting performance.
- Oil and air lubricated direct drive spindle, high speed running smoothly and low vibration for a long time, high quality of surface finishing.

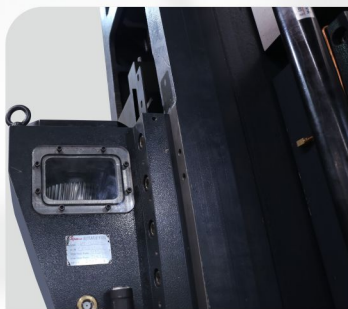

- Two step gear head
Optional two-step gear head for spindle

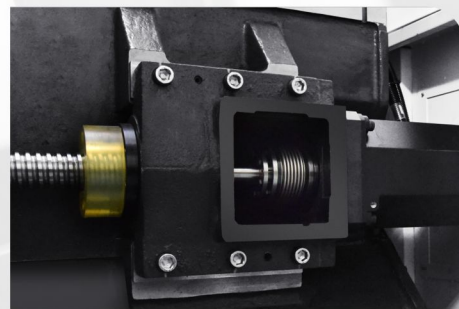

- 3 axis servo motor direct driven structure
Avoid the transmission gap of the reduction driven structure



- Standard spindle
BBT50-6000 Direct drive
Optional spindle
1.BBT50-10000 Direct drive
2.HSK-A100-12000 Direct drive
3.HSK-A63-20000 Built-in type

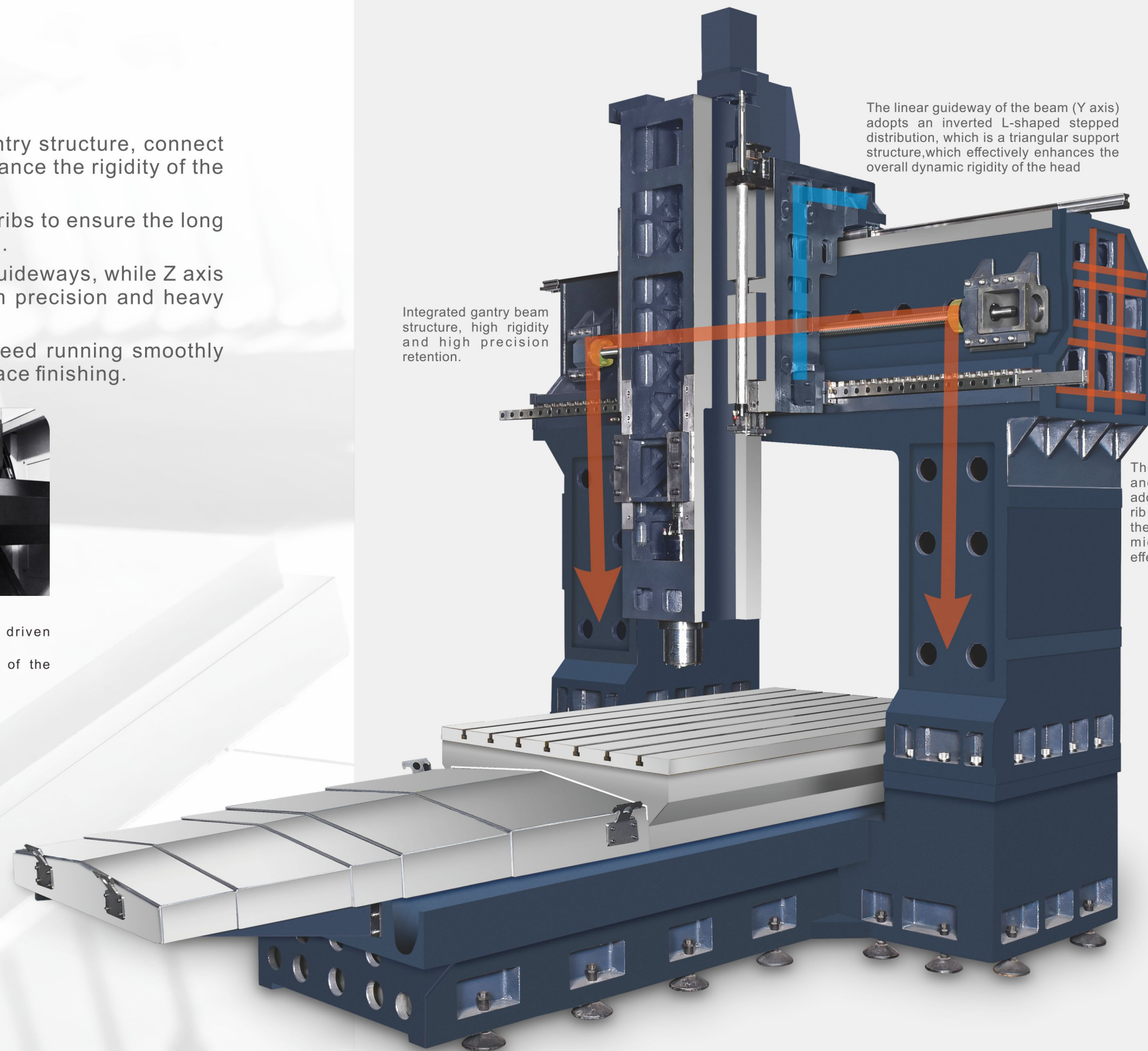

Integrated gantry beam structure, high rigidity and high precision retention.

The linear guideway of the beam (Y axis) adopts an inverted L-shaped stepped distribution, which is a triangular support structure, which effectively enhances the overall dynamic rigidity of the head

The base, worktable, and gantry beam all adopt a double-layered rib structure to control the depression in the middle of the beam effectively.

05

HIGH SPEED HIGH HEAVY CUTTING GANTRY MACHINING CENTER

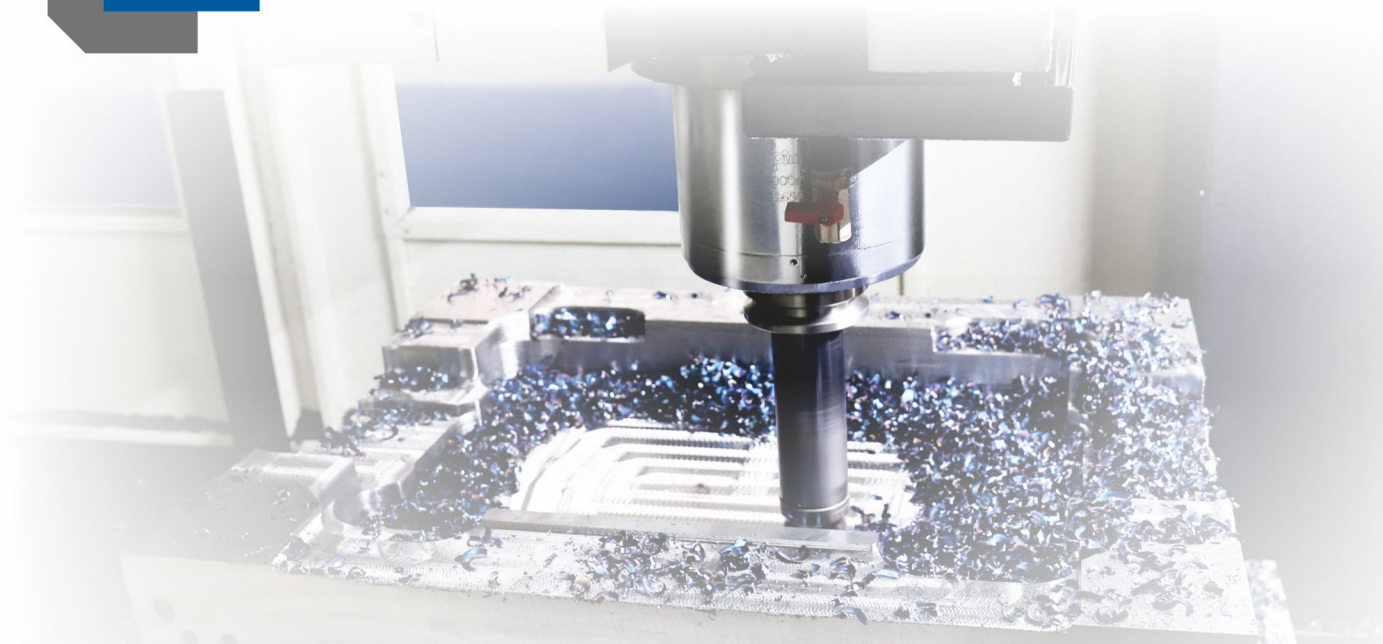

High rigidity Heavy cutting High precision

Cutting Parameter	Materials	V series	VP series	B series
Metal removal rate (milling)	S45C	717cm/min	440cm/min	1056cm/min
Max. drilling diameter	S45C	φ50	φ35	φ60
Max. tapping diameter	S45C	M42*4.5	M24*2.5	M48*5

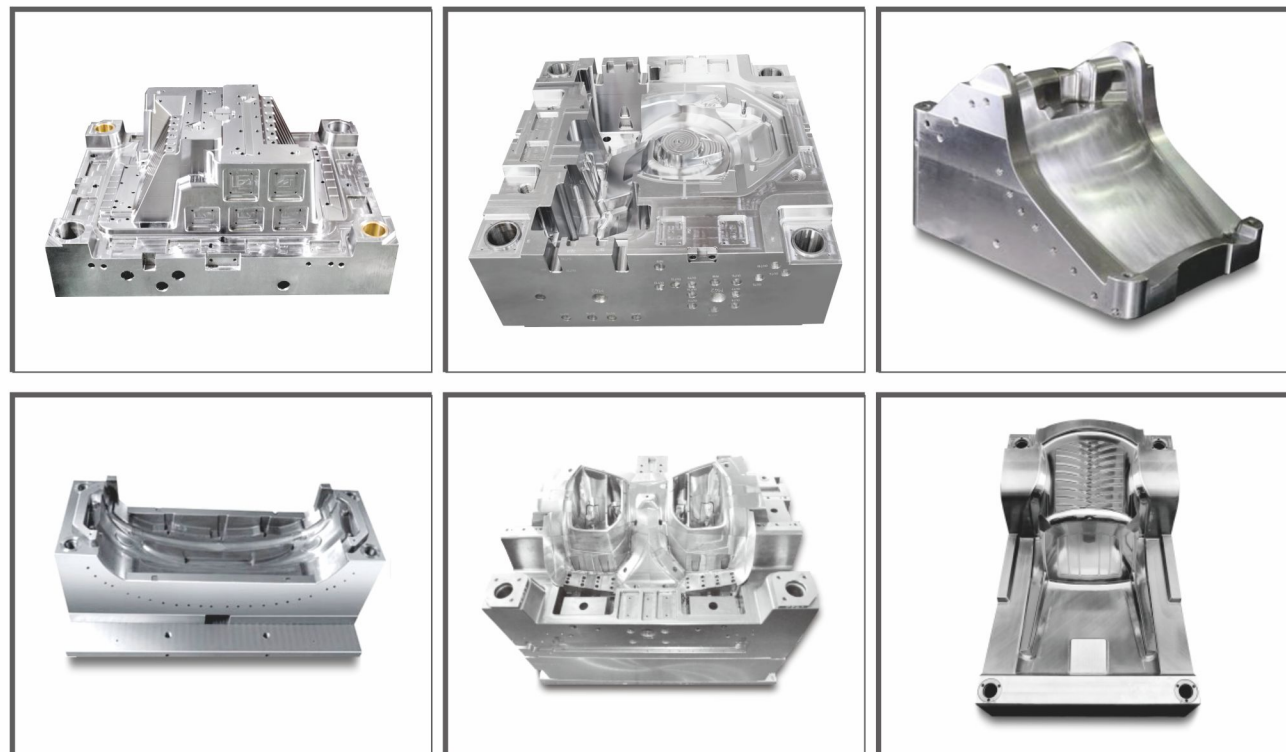

Max. processing range and load

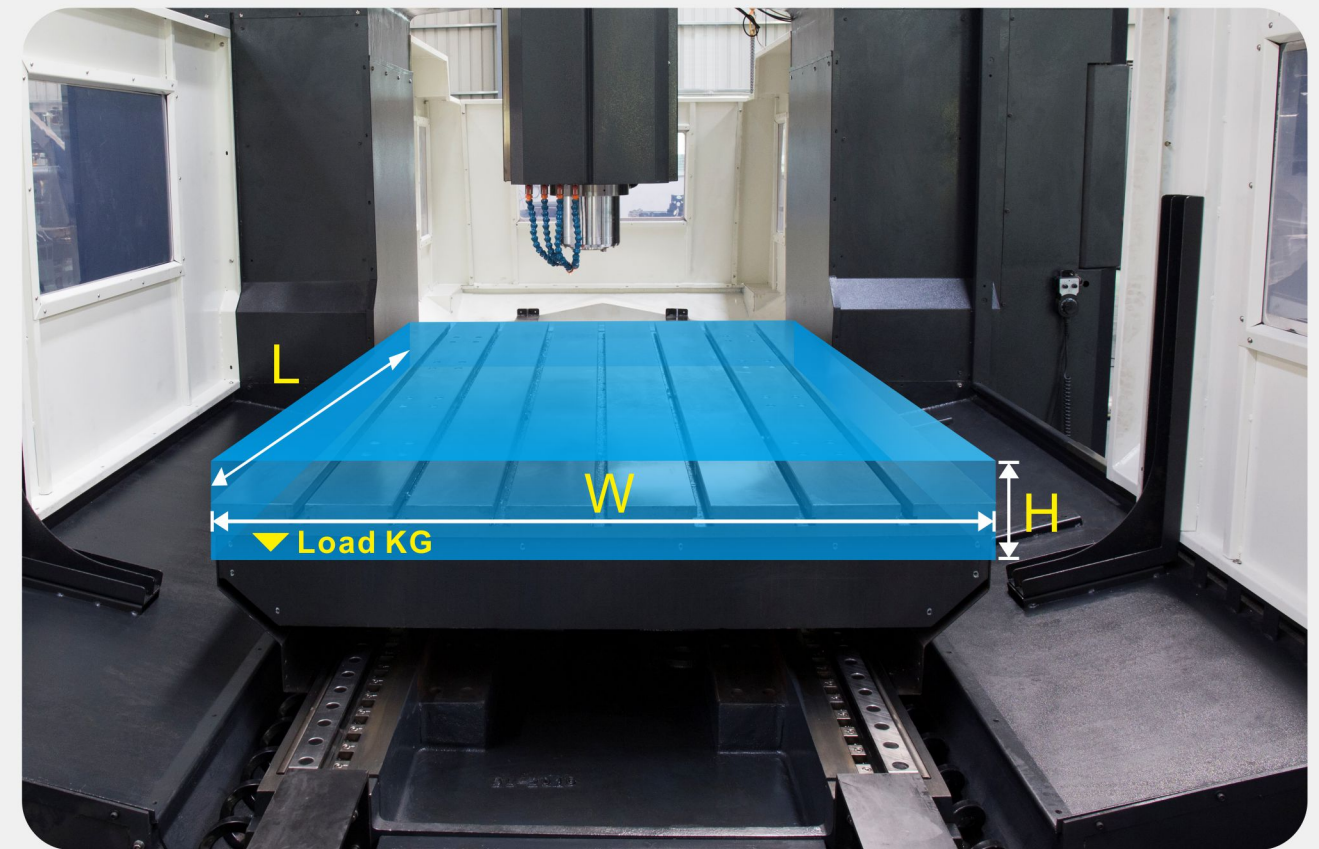

Model	Unit	L	W	H	Load	Model	Unit	L	W	H	Load
BF-1613V	mm	1600	1400	600	3000KG	BF-2518L	mm	2600	1800	900	12000KG
BF-2016V	mm	2000	1600	800	5000KG	BF-3023L	mm	3200	2300	1000	12000KG
BF-2513V	mm	2400	1400	600	4000KG	BF-3026L	mm	3200	2600	1000	16000KG
BF-2518V	mm	2600	1800	900	8000KG	BF-4023L	mm	4200	2300	1000	16000KG
BF-2016L	mm	2200	1600	800	5000KG	BF-4026L	mm	4200	2600	1000	22000KG

Output [kW]

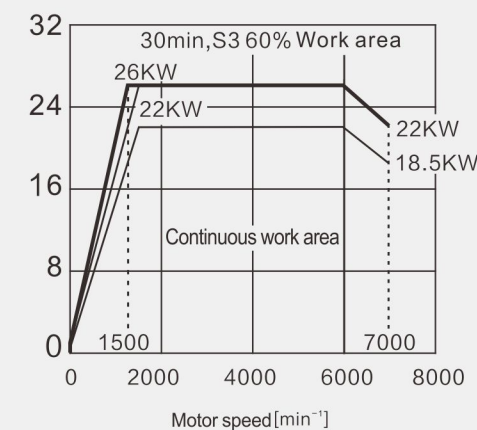

Torque [N.m]

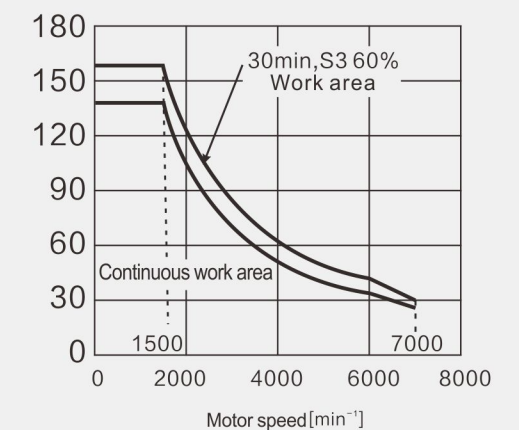

Standard spindle motor power/torque characteristics

06

GANTRY MACHINING CENTER OPTIONAL CONFIGURATION



Mitsubishi M80A/M800 Controller



Fanuc 0i-MF Type 1/3/31i-B Controller

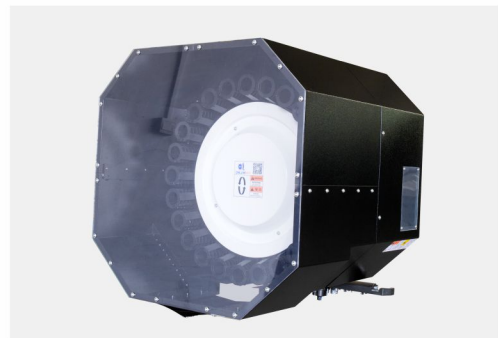

Tool magazine
(Auto tool exchange system)



Chain type chip conveyor



CTS system



Tool setter (Mechanical / laser type)

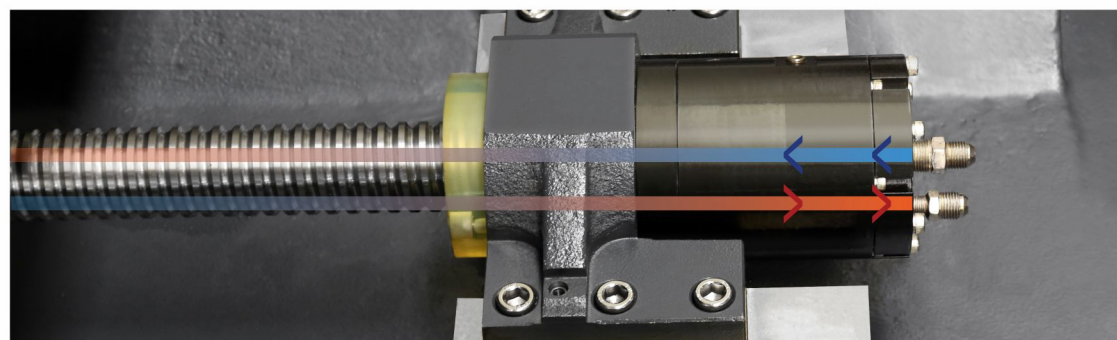

3 axis optional ball screw and bearing circulation oil cooling system

Machine dimension drawing

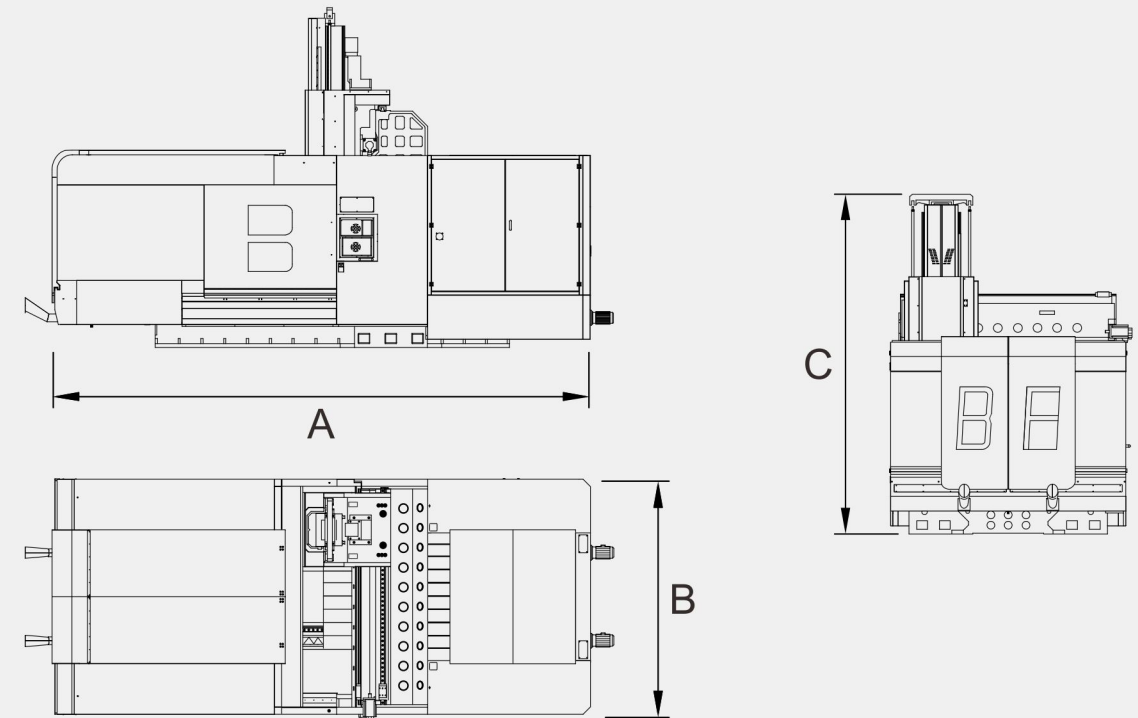

Model	Unit	A	B	C
BF-1613V	mm	5100	3500	4000
BF-2016V	mm	7060	4150	4260
BF-2513V	mm	6900	4000	4000
BF-2518V	mm	7500	5000	4600
BF-2016L	mm	6400	4800	4200

Model	Unit	A	B	C
BF-2518L	mm	7800	4800	4600
BF-3023L	mm	8500	5000	4800
BF-3026L	mm	8500	5300	5000
BF-4023L	mm	11000	5000	4800
BF-4026L	mm	11000	5300	5000

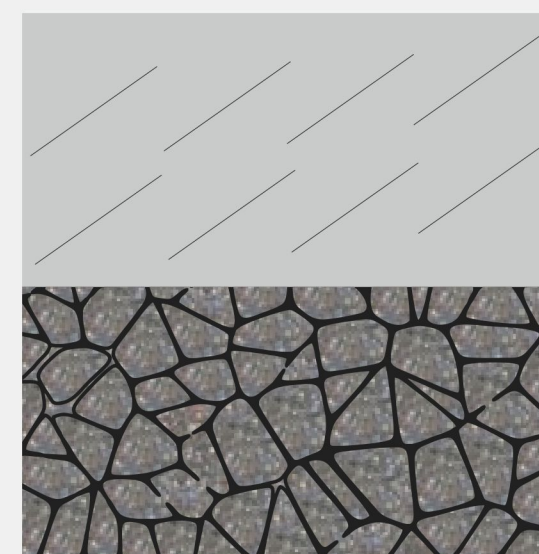

Foundation requirements:

1. The thickness of the foundation concrete is more than 500mm.
2. The following concrete is paved with more than 300mm cobblestone.
3. Foundation range flatness is within 5mm.
4. Foundation resistance above 10 ton/m.

07

HIGH SPEED HIGH PRECISION MACHINING CENTER SERIES



Machine parameters	Unit	BF-1613VP	BF-2016VP	BF-2518VP
3 axis travel (X*Y*Z)	mm	1600x1400x600	2000x1600x800	2600x1800x900
Worktable	mm	1650x1100	2200x1300	2700x1400
T-slot spec	mm	7-18x150	7-22x190	7-22x180
Maximum load	kg	3000	5000	8000
Gantry width	mm	1430	1630	1750
Spindle nose to table	mm	180-780	200-1020	250-1150
X/Y/ Z axis motor power	KW	3.0/3.0/3.0	7.0/4.5/4.5	7.0/7.0/7.0
X/Y/Z rapid feed	m/min	20/20/20	15/15/15	15/15/12
Controller	Mitsubishi M80/Fanuc 0i-MF PLUS/Siemens 828D			
Spindle taper and spec		BBT40-45°	BBT50-45°	BBT50-45°
Spindle speed	rpm	12000	10000	6000
Spindle motor power	kw	11/15	15/18.5	22/26
Positioning accuracy	mm	± 0.005/300	± 0.005/300	± 0.005/300
Repeat positioning accuracy	mm	± 0.003/300	± 0.003/300	± 0.003/300
Air pressure spec	kg/cm	6 ~ 7bar	6 ~ 7bar	6 ~ 7bar
Dimension	mm	5100x3500x4000	7060x4150x4260	7500x5000x4600
Weight	kg	13000	18000	28000

08

HIGH SPEED HEAVY CUTTING MACHINING CENTER



Machine parameters	Unit	BF-1613V	BF-2016V	BF-2513V	BF-2518V	BF-2016L
3 axis travel (X*Y*Z)	mm	1600x1400x600	2000x1600x800	2400x1400x600	2600x1800x900	2200x1600x800
Worktable	mm	1650x1100	2200x1300	2500x1100	2700x1400	2200x1300
T-slot spec	mm	7-18x150	7-22x190	7-18x150	7-22x180	6-22x190
Maximum load	kg	3000	5000	4000	8000	5000
Gantry width	mm	1430	1630	1430	1750	1630
Spindle nose to table	mm	180-780	200-1020	180-780	250-1150	250-1050
X/Y/ Z axis motor power	KW	3.0/3.0/3.0	7.0/4.5/4.5	4.5/4.5/4.5	7.0/7.0/7.0	7.0/4.5/4.5
X/Y/Z rapid feed	m/min	20/20/20	15/15/15	15/15/12	15/15/12	15/15/12

Controller	Mitsubishi M80/Fanuc 0i-MF PLUS/Siemens 828D					
Spindle taper and spec		BBT40-45°	BBT50-45°	BT40-45°	BT50-45°	BT50-45°
Spindle speed	rpm	12000	10000	12000	6000	6000
Spindle motor power	HP(kw)	11/15	15/18.5	11/15	22/26	22/26
Positioning accuracy	mm	± 0.005/300	± 0.005/300	± 0.005/300	± 0.005/300	± 0.005/300
Repeat positioning accuracy	mm	± 0.003/300	± 0.003/300	± 0.003/300	± 0.003/300	± 0.003/300
Air pressure spec	kg/cm ²	6 ~ 7bar	6 ~ 7bar	6 ~ 7bar	6 ~ 7bar	6 ~ 7bar
Dimension	mm	5100x3500x4000	7060x4150x4260	6900x4000x4000	7500x5000x4600	6400x4800x4200
Weight	kg	13000	18000	17000	28000	21000

Machine parameters	Unit	BF-2518L	BF-3023L	BF-3026L	BF-4023L	BF-4026L
3 axis travel (X*Y*Z)	mm	2600x1800x900	3200x2300x1000	3200x2600x1000	4200x2300x1000	4200x2600x1000
Worktable	mm	2700x1400	3000x1800	3000x2200	4000x1800	4000x2200
T-slot spec	mm	7-22x180	10-22x180	11-26x200	10-22x180	11-26x200
Maximum load	kg	8000	12000	16000	16000	22000
Gantry width	mm	1750	2350	2650	2350	2650
Spindle nose to table	mm	200-1100	280-1280	280-1280	280-1280	280-1280
X/Y/ Z axis motor power	KW	6.0/3.0/3.0	7.0/7.0/7.0	7.0/7.0/7.0	7.0/7.0/7.0	7.0/7.0/7.0
X/Y/Z rapid feed	m/min	15/15/12	12/12/12	12/12/12	12/12/12	12/12/12

Controller	Mitsubishi M80/Fanuc 0i-MF PLUS/Siemens 828D					
Spindle taper and spec		BT50-45°	BT50-45°	BT50-45°	BT50-45°	BT50-45°
Spindle speed	rpm	6000	6000	6000	6000	6000
Spindle motor power	HP(kw)	5/18.5	22/26	22/26	22/26	22/26
Positioning accuracy	mm	± 0.005/300	± 0.005/300	± 0.005/300	± 0.005/300	± 0.005/300
Repeat positioning accuracy	mm	± 0.003/300	± 0.003/300	± 0.003/300	± 0.003/300	± 0.003/300
Air pressure spec	kg/cm ²	6 ~ 7bar	6 ~ 7bar	6 ~ 7bar	6 ~ 7bar	6 ~ 7bar
Dimension	mm	7800x4800x4600	8500x5000x4800	8500x5300x5000	11000x5000x4800	11000x5300x5000
Weight	kg	28000	30000	35000	36000	42000