

BF-V6

HIGH PRECISION MACHINERY MANUFACTURER



QUALITY COMES FROM CONFIGURATION, SERVICE COMES FROM HEART

HONGKONG BAOFENG PRECISION MACHINERY CO.,LTD. ④ Hongkong: Room B1, 2/F, Mei Hing Industrial Building, 16-18 Hing Yip Street, Kwun Tong, Kowloon, Hong Kong.
DONGGUAN BAOKE PRECISION MACHINERY CO.,LTD. ④ Production base 1: No.63, XinMaLian Xintai road, Dalang Town, DongGuan, China.
HUBEI BAOKE INTELLIGENT EQUIPMENT CO.,LTD. ④ Production base 2: No.8, CaiBian South Second street, Dalang Town, DongGuan, China.
④ 0769-85633926 ④ Production base 3: East Optics Valley High-end Tool and Mold Industrial Zone, Optics Valley Avenue No.1, Tieshan District, Huangshi, Hubei, China.
④ 0769-82787859
④ info@baofengmachine.com
④ http://www.baofengmachine.com/

DONGGUAN BAOKE PRECISION MACHINERY CO.,LTD.

Feed & Travels

48/48/48 **600/500/500**
X/Y/Z (m/min) X/Y/Z (mm)

Linear guideway width X/Y/Z(mm)

35/35/45



24
Tools

ATC adopt unclamp-clamp in advance technology
Tool change time 1.75S (T-T)



3 sliders

Spindle nose to table
130-630mm
Max load on table
400KG

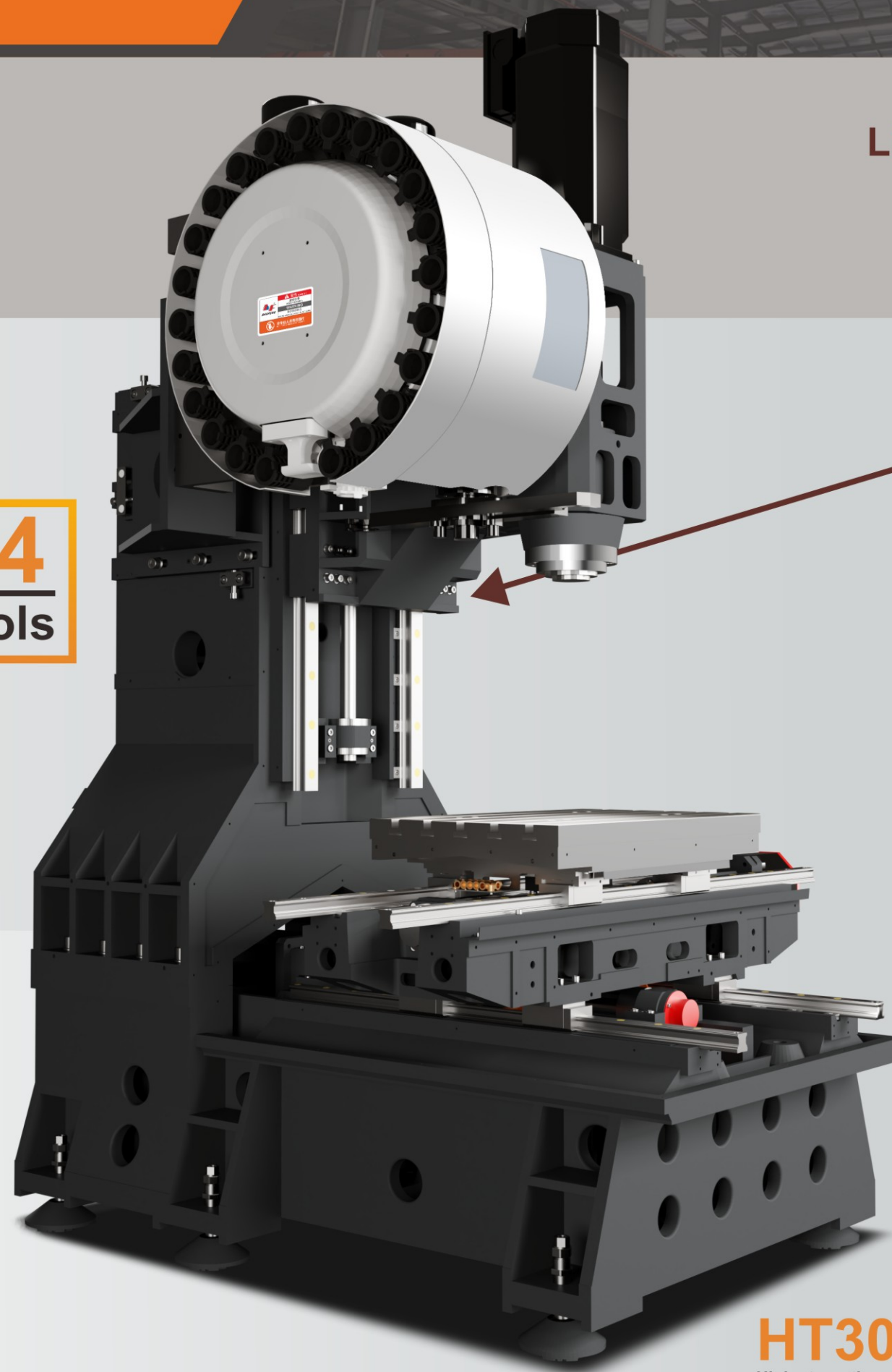
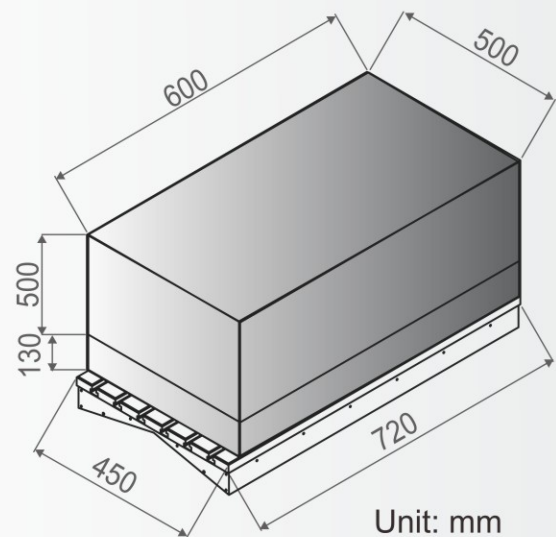

HT300

High strength resin sand type gray cast iron

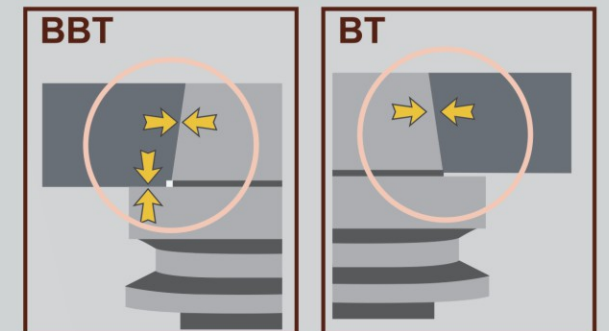

BAOFENG Big Plus spindle

Fanuc

Spindle BBT40 12000rpm

15KW/95.5NM(S2-15min S3/S6-25%)

β II 12/12000-B β II T 12/12000-B(CTS)-Optional

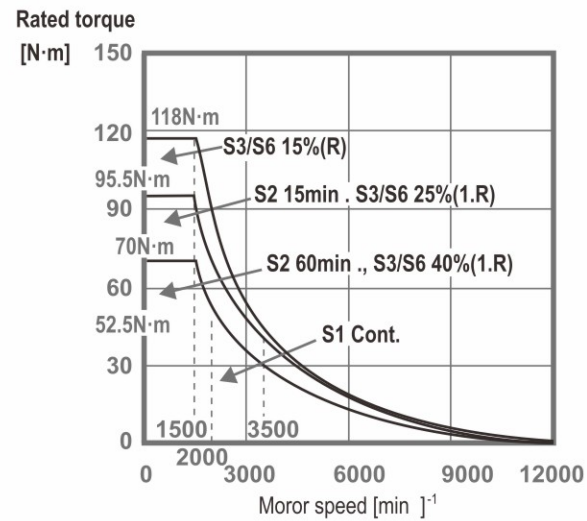
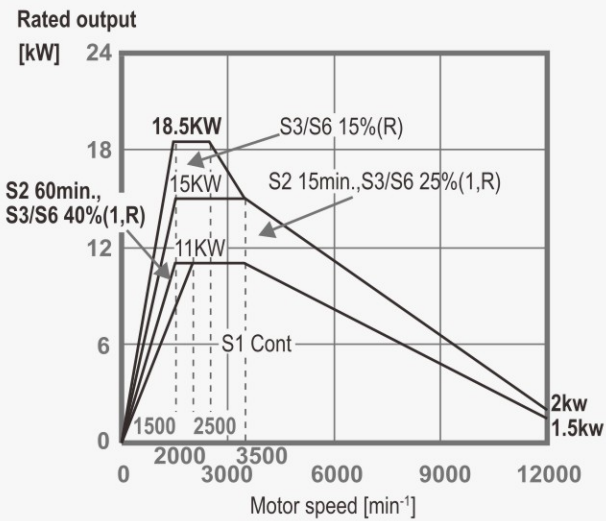

Mitsubishi

Spindle BBT40 12000rpm

15KW/95.5NM(S2-15min S3-25%)

SJ-DG11/120-14T SJ-DG11/120-14T-S(CTS)-Optional

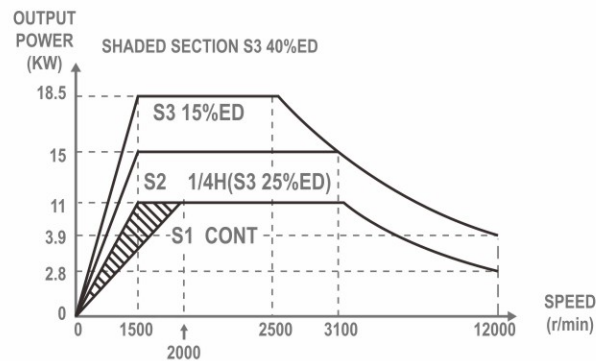

OUTPUT POWER-SPEED CHARACTERISTIC NORMAL

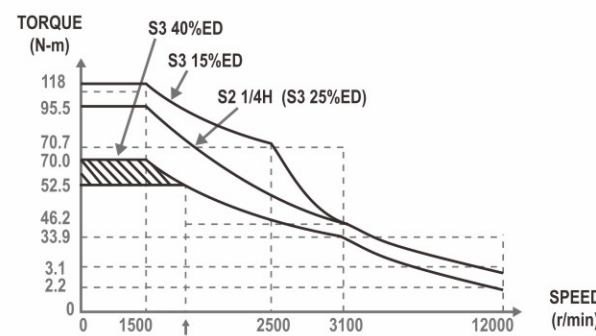

TORQUE-SPEED CHARACTERISTIC NORMAL

Chip removal capacity



Limit face milling

Material: P20
Tool: D50/3 flute mills
Feed: 2400mm/min
Rotation speed: 1000rpm



Material: 6061 aluminum
Minimum M1
Maximum M26 (负载86%)

Chip removal rate **230.4cm³/min**

AE 40mm

Max AP 2.6mm

Cutting capacity



Drilling parameter

Material: 6061 aluminum
Pore diameter: 1.6-1000 pcs
Feed: 600mm/min
Rotation speed: 6000rpm
G81 Z-1.6
G83 Z-8.0 Q3.0

G81: 57S/100PCS

G83: 4m27S/100PCS

Taping parameter

Material: 6061 aluminum
M2/100 PCS
Feed: 3000mm/min
Rotation speed: 1200rpm
G84 Taping to the end: 6
G84 Peck taping: 8, 3mm/time

G81: 2m32S/100PCS

G84(Peck taping): 6m23S/100PCS

Surface quality test



Material: NAK80
Tool: N8R0.5
NS R3
Feed: 2300
Spacing: 0.07
Time: 3h56min19s

X/Y Tolerance: ≤0.012mm

Z Tolerance: ≤0.008mm

Surface smoothness: Ra1.3

Standard Accessories

- FANUC 0i-MF Plus(10.4 ") controller
- Or Mitsubishi M80(10.4")controller



Program transfer Tool setter Accuracy adjustment Home page Auto edge searching



- ATC + Full enclosed ATC cover
- Ring spray coolant+ LED light

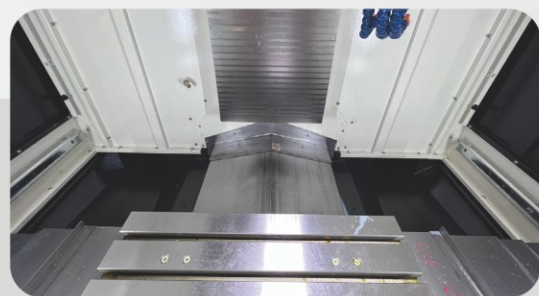

- Chassis flushing system



- Spindle oil coolant



Optional Accessories

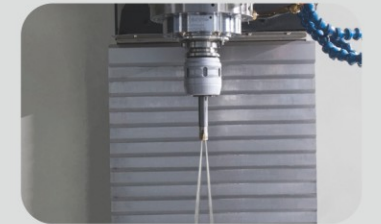

Coolant through spindle



Tool setter



4th axis rotary table



5th axis rotary table

Item	Unit	BF-V6
Travel	X axis travel	mm 600
	Y axis travel	mm 500
	Z axis travel	mm 500
Distance	Spindle center to column	mm 520
	Spindle nose to table surface	mm 130-630
Worktable	Worktable area	mm 720x450
	Dimension of T-slot	mm 5-18x80
	Max.worktable load	kg 400
Spindle	Spindle taper	BBT40
	Spindle motor/ (S2-15min S3/S6-25%) (Fanuc)	kw/NM 15/95.5
	Spindle motor/torque (S2-15min S3-25%) (Mitsubishi)	kw/NM 15/95.5
	Max.spindle speed	rpm 12000
Axial	Rapid feed rate-X/Y/Z (Fanuc)	m/min 48/48/48
	Rapid feed rate-X/Y/Z (Mitsubishi)	m/min 48/48/48
	Axis acceleration	g 1.0
	Axis feed motor-X/Y/Z (Fanuc)	kw 3.0/3.0/3.0
	Axis feed motor-X/Y/Z (Mitsubishi)	kw 2.0/2.0/3.0
	X axis screw (Dia./pitch)	mm 36/16
	Y axis screw (Dia./pitch)	mm 36/16
	Z axis screw (Dia./pitch)	mm 36/16
Tools	Linear guide width(X/Y/Z)	mm 35/35/45
	Max.tool length	mm 300
	Max.tool weight	kg 7
	Tool magazine capacity	24
	Max.tool(full)	mm 80
	Max.tool diameter(without adjacent tools)	mm 150
	Tool change time	sec. 1.75
Accuracy (ISO230-2)	Pull stud angle	deg. BT40/45°
	Tool selection method	Proximity tool selection
	Positioning accuracy(bi-direction)	mm ±0.003/300
Machine	Repeat positioning	mm ±0.002/300
	Power requirement	KVA 25
	Min/Max.air pressure	kg/cm ² 5-7
	Coolant tank capacity	L. 280
	Std.NC controller(Fanuc)	MITSUBISHI M80
	Std.NC controller (Mitsubishi)	Fanuc Oi-MF PLUS
	Floor space requirement	mm 2200x2775
Machine height	mm 2730	
Machine weight	kg 4500	

Standard Accessories:

- FANUC Oi-MF(10.4 ") controller Or Mitsubishi M80(10.4")controller
- Fully enclosed metal cover
- 24T tool magazine
- Spindle oil coolant
- LED working light
- Machine head LED light
- Heat exchanger
- Chassis flushing system
- Auto Central lubrication system
- Alarming light
- Auto power off
- Safety switch
- Rigid tapping
- MPG
- Basic installation sets
- Leveling pads
- Air gun
- High pressure water gun

Optional Accessories

- Air conditioner for electric cabinet
- Auto door
- Oil mist collector
- 20KG/30KG CTS
- BT40 side milling tool holder
- Tool setter(for tool length)
- Tool setter(for tool length & radius)
- Laser tool setter
- Auto part measuring
- 4th axis rotary table (Max.φ255)
- 5th axis rotary table (Max.φ210)

Machine Sheet Metal Option



Tool Specification

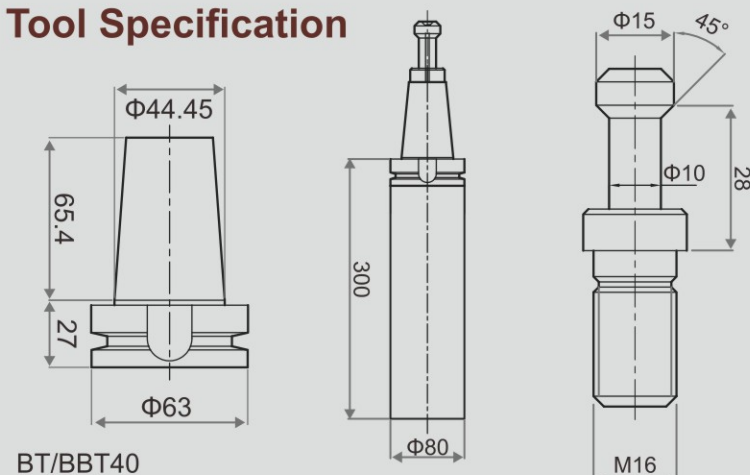

BT/BBT40
 Max.tool weight:7.0KG
 Max.tool Dia.:80mm Max.tool length:300mm

	Machining center	
	M80 series	
	TypeA	TypeB
Max Number of Axes (NC Axes+Spindles+PLC axes)	11	9
"Max. Number of NC Axes(In Total of All the Part Systems)"	8	5
Max. Number of Spindles	2	2
Max. Number of PLC Axes	6	6
Number of Simultaneous Contouring Control Axes	4	4
Max. Number of NC Axes in a Part System	8	5
Max. Number of Part Systems	2	1
Control Unit-side High-speed Program Server Mode	—	—
Display Unit-side High-speed Program Server Mode	○	○
Front-side SD Card Mode	○	○
Least Command Increment	0.1μm	0.1μm
Least Control Increment	1nm	1nm
Max. Number of Tool Offset Sets	400 sets	400 sets
Max. PLC Program Capacity[Steps]	64000	32000
Multiple-project PLC (Max. Number of Projects)	3	1
Touch Gesture Operation	○	○
Level Management Operation Authority Function	○	○
Workpiece Coordinate System Offset	—	—
3D Program Check	○	○
Interactive Cycle Insertion	—	—
Multiple-spindle Synchronization	—	—
Spindle Superimposition Control	—	—
High-accuracy Control	○	○
High-speed High-accuracy Control I	○	○
High-speed High-accuracy Control II	○	—
SSS Control	○	—
Tolerance Control	○	—
Variable-acceleration Pre-interpolation Acceleration/Deceleration	—	—
OMR-FF Control	○	○
Rapid Traverse Block Overlap	○	○
Spindle-mode Servo Motor Control	○	○
Real-time Tuning 1(Speed Gain Switch)	○	—
Real-time Tuning 1 (Rapid Traverse Time Constant Switch)	○	—
Tool Center Point Control	—	—
Inclined Surface Machining Command	○	—
3-dimensional Manual Feed	○	—
R-Navi	○	—
CC-Link (Master/Local)	□	□
PPROFIBUS-DP (Master)	□	□
Ethernet/IP (Scan)	□	□
MES Interface Function	○	○
EcoMonitorLight Connection	□	□
Machine Group-based Alarm Stop	○	—
Smart Safety Observation	—	—

○Standard △Option □Selection —no option Please refer to the specification sheet for details.

Controlled axis / Accuracy compensation function		Type 5
Control axes	3 axes(X,Y,Z)4 axes (X,Y,Z,B)	○5
Simultaneous controlled axes	3 axes (Max. 4 axes)	○
Least setting unit	X,Y,Z axes: 0.001mm(0.0001inch) B axis: 1deg[0.001]deg	○
Interpolation straightness compensation		☆
AI Thermal displacement compensation		☆
Ball screw thermal expansion compensation		○
Inch/Metric Conversion		○
Linear scale optional closed loop	Add linear scale interface communication module(☆)	○
Double positions feedback	Optional when with linear scale(☆)	☆
Operation		
3D rigid tapping retraction		-
3D manual feed		-
3D coordinate exchange		-
Inclined surface indexing command		-
Handwheel retraction		○
Multiple steps skip		○
Processing preparation support function	Edge search	○
Small diameter deep-hole drilling cycle		☆
Dynamic graphics display		○
Program restart		○
Selected program block skip		☆
Memory card program editing and running	63 PCS	○
USB memory program running	USD DNC machining	-
iHMI		-
MANUAL GUIDE 0i		☆
MANUAL GUIDE i		-
Power-off retraction		○
Handwheel interruption		○
Interpolation function		○
Nano interpolation		○
Skip	G31	○
One-way positioning	G60	○
Normal direction control	Application 1: friction welding	☆
Tool front point control (TCP)	multi-axis machining	-
Mold package option		
High-accuracy program command	Include least setting Increment A-E	○
Pre-read program block		○
AICC I	40 block AICC I	○
AICC II	200 block AICC II	○
	400 block AICC II	-
Jerk control		○
Smooth tolerance control		○
Machining condition/mode selection		○
Smart adaptive Control		☆
Program input		
Optional block skip	9 blocks	☆
Auxiliary/spindle function		
Cs contour control	Serial communication spindle position control	○
Spindle orientation	M19(S_ _ _)	○
Tool function / tool offset		○
Tool life management		○
Tool broken detection		○
Editing function		
Workpiece program storage	5,120m(2MB)	○
Extended part program editing	Copy, move and change of NC program	○
Data server function		☆
Setting, display and diagnosis		
Multi language display	Support 24 languagesz	○9

Note: ○Standard ●Required ☆ Optional -Not Applicable Please refer to the specification sheet for details.

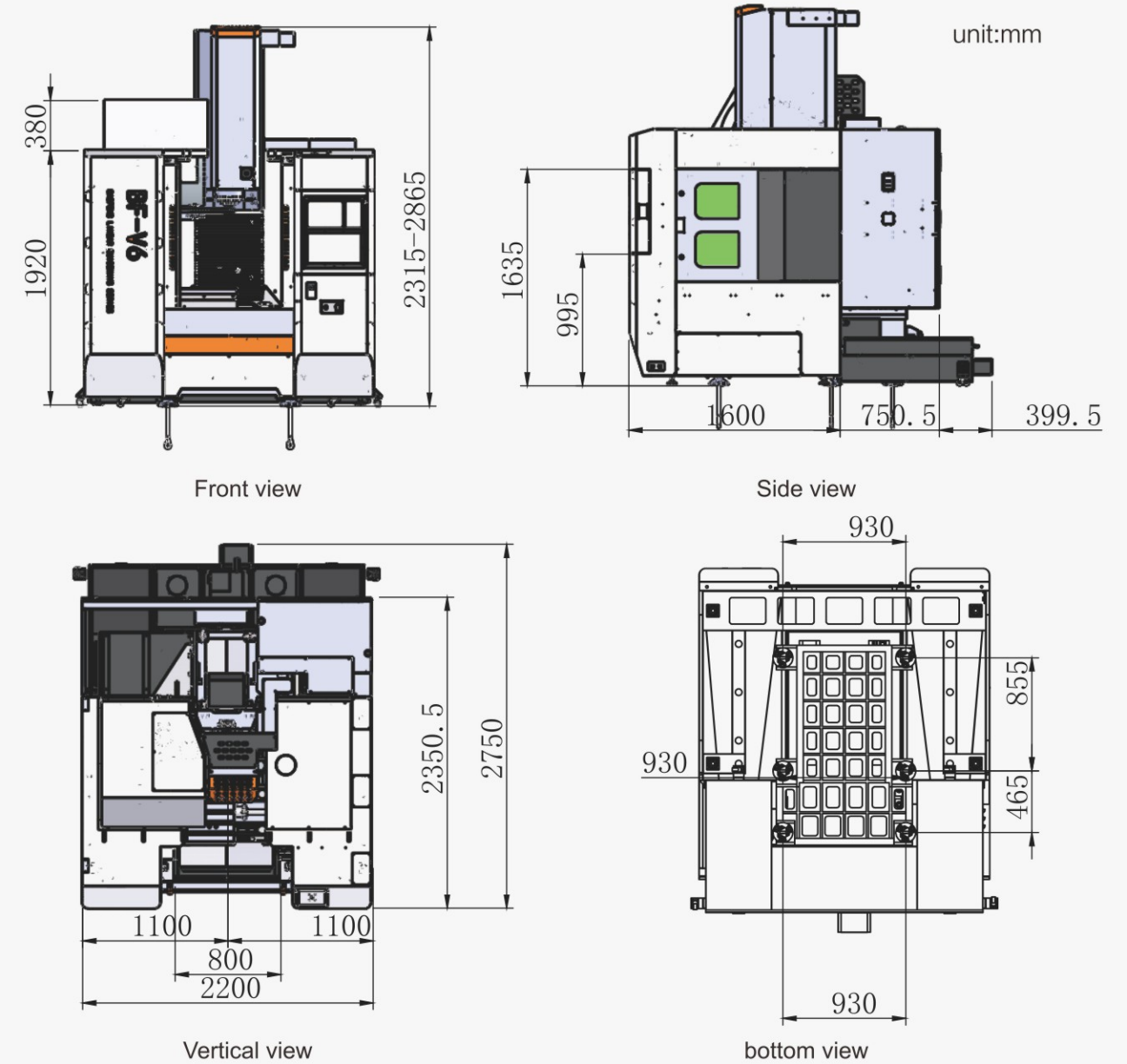

Installation preparations

NO	Project	Requirement	Remark
1	Confirm entry width and height	Enough space for equipment	External dimensions of the equipment +500mm
2	Power cable line	4*6mm ²	Sufficient to connect to the machine
3	Compressed air access	Air source filtration accuracy 100μm, air pipe outer diameter 10mm	External air pipe should be enough to connect to the machine interface
4	Shipping solution	1.Confirmation of the transport method according to the road conditions around the plant and the largest packing dimensions 1.Confirmation of equipment access according to the actual conditions	